

# Pennsylvania Work Zone Pocket Guide for Municipalities & Utilities



## Introduction & Reference

Primary Resources .....	5
Other Useful Resources .....	5

## Worker Safety Considerations

Worker Definition .....	6
Worker Safety – Key Elements .....	6
Worker Safety – Improvements .....	7
Worker Safety – Apparel .....	8

## Work Zone Device Guidelines

TTC Zone Devices .....	9
Sign Size and Color .....	10
Sign Placement Guidelines .....	11
Sign Layout .....	15
Channelizing Device Placement .....	22

## Using and Adjusting Typical Applications

PATA Figure 10a .....	25
Typical Application 18 .....	29
PATA Figure 11c.....	31
PATA Figure 11e .....	33
PATA Figure 12 .....	35
Options for Mowing.....	37

## Work Zone Checklist for Short Term Set-ups

Planning / Design.....	38
Preparing for Field .....	38
In Field .....	38

## Introduction & Reference

This Handbook was developed for use by persons involved in maintenance, construction, or utility work on or along Pennsylvania's roadways. The intention is that this Pocket Guide will serve as an accessible source of information covering common conditions work crews may encounter. While no single document can provide the breadth and depth of information necessary to cover every potential condition encountered along every segment of roadway in the Commonwealth, this document has been developed as a handy reference for most applications needed under most conditions.

The information in this Pocket Guide was compiled from available resources including PennDOT and Federal Highway Administration publications, and is intended to illustrate the guidelines for proper work zone traffic control, but is not a standard.

Each of these publications addresses facets of temporary traffic control issues in greater depth than presented here. Each section of this Pocket Guide indicates the source of the material presented, offering users a convenient reference. In those specific instances where a real condition is unusual and not covered here, these publications are available for additional review and study.

The publications consulted in developing this Handbook are listed below.

### **Primary Resources**

- *Manual on Uniform Traffic Control Devices (MUTCD)*, Federal Highway Administration
- PUB 212, *Official Traffic Control Devices*, Pennsylvania Department of Transportation
- PUB 213, *Temporary Traffic Control Guidelines*, Pennsylvania Department of Transportation

### **Other Useful Resources**

- PUB 35, *Approved Construction Materials (Bulletin 15)*, Pennsylvania Department of Transportation
- PUB 46, *Traffic Engineering Manual*, Pennsylvania Department of Transportation
- PUB 234, *Flagging Handbook*, Pennsylvania Department of Transportation
- PUB 236M, *Handbook of Approved Signs*, Pennsylvania Department of Transportation
- PUB 408, *Standard Specifications*

## **Worker Safety Considerations**

PUB 213 defines workers as “a person on foot whose duties place him or her within the right-of-way of a street or highway, pathway, such as a highway construction and maintenance forces, survey crews, utility crews, responders to incidents within the highway right-of-way, and law enforcement personnel when directing traffic, investigating crashes, and handling lane closures, obstructed roadways, and disasters within the right-of-way of street, highway, or pathway”.

### **Worker Safety - Key Elements**

These key elements of worker safety should be considered by TTC planners:

- Worker training
- Worker safety apparel
- Properly placed temporary traffic barriers
- Reduction in the speed of vehicular traffic
- Properly planning the activity area
- Conduct a basic hazard assessment of the work area

## **Worker Safety – Improvements**

In addition to following MUTCD and PUB 213 TTC requirements, there are several options available to improve worker safety. These include:

- Shadow vehicle;
- Road closure;
- Law enforcement;
- Lighting;
- Special devices such as:
  - rumble strips,
  - changeable message signs,
  - beacons,
  - flags, and,
  - warning lights (MUTCD 6D.03).

## Worker Safety - Apparel

Guidance on safety apparel for all workers can be found in both the MUTCD and in PUB 213.

PUB 213 requires safety apparel for workers on Pennsylvania roadways. In the General Notes section, note number 9, PUB 213 reads:

“All workers including flaggers shall wear a high-visibility fluorescent orange or yellow-green apparel with retroreflective material that meets the latest ANSI/ISEA publication entitled American National Standard for High-Visibility Safety Apparel and Headwear for Class 2 risk exposure anytime day or night. Class 3 high-visibility should be considered for additional flagger visibility at night. During inclement weather, high-visibility fluorescent rain gear may be used. If FHWA amends or modified their regulation, the amendment will take effect on the date specified by FHWA.”



Example: ANSI Class 2 Safety Apparel is available in many styles and materials

# Work Zone Device Guidelines

## TTC Zone Devices

Chapter 6F of the MUTCD contains guidance about the devices used in Temporary Traffic Control (TTC) zones. Generally, TTC devices include: signs; channelizing devices such as cones, drums and barricades; and lighting.

For Pennsylvania-specific TTC devices, refer to:

- PUB 212 - Official Traffic Control Devices;
- PUB 213 – Temporary Traffic Control Guidelines;
- PUB 236M - Handbook of Approved Signs.
- Sign supports shall be crashworthy, must be PennDOT approved vendors, and listed in PUB 35 (Bulletin 15). This publication is updated regularly, so it is best accessed online at:

[ftp://ftp.dot.state.pa.us/public/pdf/BOCM\\_MTD\\_LAB/PUBLICATIONS/PUB\\_35/BULLETIN\\_15.pdf](ftp://ftp.dot.state.pa.us/public/pdf/BOCM_MTD_LAB/PUBLICATIONS/PUB_35/BULLETIN_15.pdf)

## **Sign Size and Color**

Temporary signs must follow PennDOT's convention for size and color. Maintaining such standards assists road users with quick recognition and helps form expectations for appropriately approaching temporary traffic control zones.

From PUB 213:

- All signs shall be 36" x 36" for conventional roadways;
- The ROAD WORK AHEAD sign (W20-1) or ROAD WORK NEXT \_\_ MILES (G20-1) signs are the standard advance signs. These signs may be used as alternatives:
  - EMERGENCY AHEAD (W25-1),
  - SURVEY CREW (W21-6),
  - MOWING NEXT \_\_ MILES (W21-14), and
  - BRIDGE INSPECTION AHEAD (W21-11);

Example: Sign Obstructing Sight Distance from  
a Park Driveway



**Sign Placement Guidelines**

Signs should be located on the right side of the roadway unless otherwise specified, however supplemental signs may be placed on left side of the roadway. Signs are to be placed at right angles to roadway. When placing temporary signs, visibility of existing roadway features must be maintained. Do not obstruct view of existing traffic control devices, and consider hills and sharp turns and their impact on sign visibility. Also, do not obstruct sight distance from driveways or intersections.



Avoid placing signs in intersections or other conflict areas.

Avoid placing signs behind curves and obstructions

Example of appropriate sign placement



Example of poor sign spacing and placement



Many roads will have situations that require the use of judgment in sign placement.



If the queues (line of vehicles) extend beyond the advanced signing for the work zone, additional signing may be appropriate and is required on higher speed highways (PUB 213 note 31).



## **Sign Layout**

Guidance regarding sign layout within temporary traffic control zones is found in PUB 213. 'PATA Sign Layout' is the page within PUB 213 that shows the standard lateral dimensions of sign layout, with typical dimensions for both rural and urban roadways. Also included on that page are notes regarding sign layout:

- Signs located on both the left and right sides of the roadway shall conform to these guidelines.
- Higher mounting heights are desirable and may be necessary where construction equipment, material, or other obstructions such as parking or pedestrian activity are present.
- In urban areas, a clearance of 1' from the curb face is permissible where sidewalk width is limited or where existing poles are close to the curb.
- Within work zones, it is sometimes necessary or desirable to position signs within the roadway itself. All signs erected within a roadway or a shoulder shall be mounted on portable supports or Type III barricades.
- Any supplemental plaque must also be centered under the sign.
- Portable sign supports shall only be used during short term operations.

---

## SIGNS MOUNTED ON PORTABLE SUPPORTS

( See Note 7 )

---

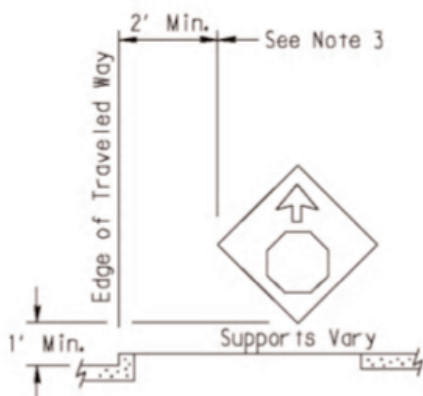
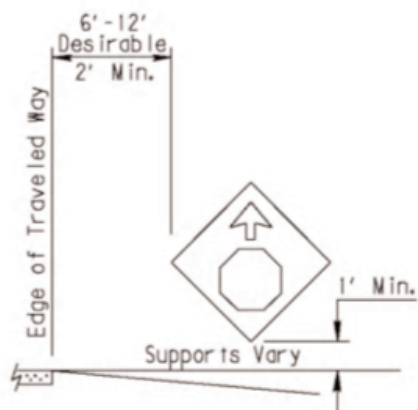

---

## SIGNS MOUNTED ON TYPE III BARRICADES

---

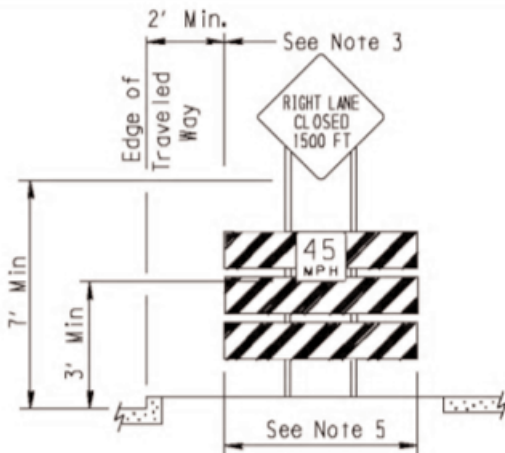
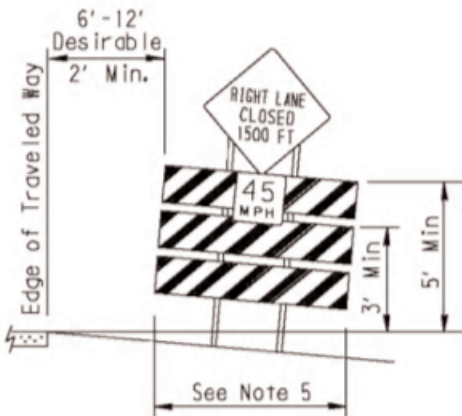

## POST MOUNTED SIGNS

---

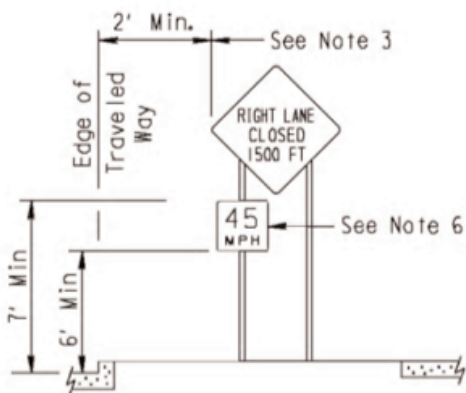

Notes from the PATA Sign Layout page in  
PUB 213

1. Signs located on both the left and right sides of a roadway shall conform with these guidelines.
2. Higher mounting heights are desirable and may be necessary where construction equipment, material, or other obstructions such as parking or pedestrian activity are present.
3. In urban areas, a clearance of 1' from the curb face is permissible where sidewalk width is limited or where existing poles are close to the curb.
4. Within work zones, it is sometimes necessary or desirable to position signs within the roadway itself. All signs erected within a roadway or a shoulder shall be mounted on portable supports or type III barricades.
5. The length of type III barricade rails shall equal or exceed the widest horizontal dimension of the widest sign installed on the barricade or a minimum of 4' whichever is larger.
6. The supplemental plaque may also be centered under the sign.
7. Portable sign support shall only be used during short term operation.



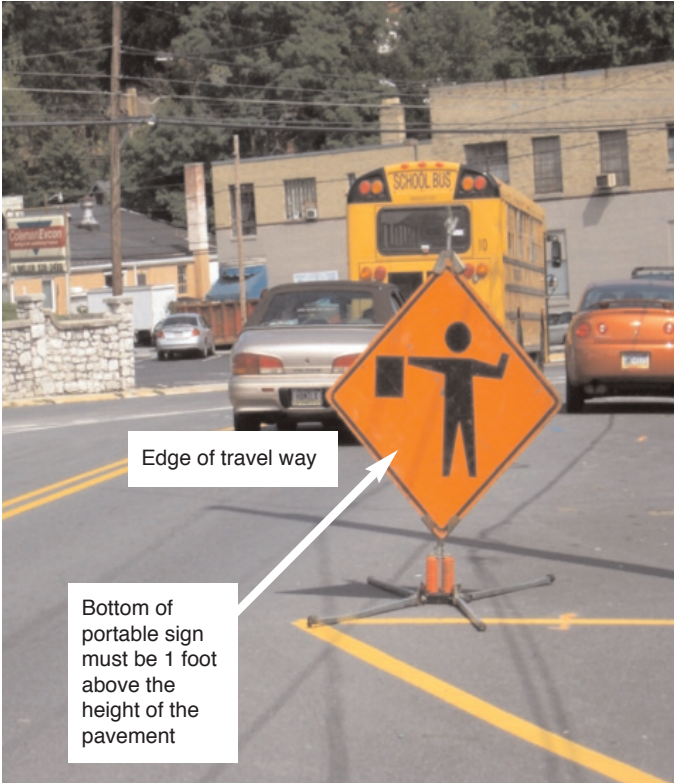

PUB 213 permits the placement of signs within a roadway, as long as portable signs are mounted on approved breakaway supports. This sign is also placed in the parking lane, not the travel way.

## **Channelizing Device Placement**

In addition to the four components of a TTC zone, the MUTCD contains guidance about tapers, which may be used in transition and termination areas. Typically, a taper is a series of channelizing devices and/or pavement markings that move traffic out of or into the normal traffic path. There are several types of tapers, including:

- Shifting taper;
- Shoulder taper;
- Merging taper;
- One lane, two-way traffic taper; and
- Downstream taper (*MUTCD 6C.08*).

The lengths of tapers should be determined using the PATA drawings found in PUB 213 page 5 of this handbook. Generally, taper lengths are associated with the speed of traffic and the lane width/shift, with lower speeds requiring shorter tapers and higher speeds requiring longer tapers

PUB 213 specifies the required spacing for channelizing devices in work zones. Remember that:

- a work zone has four main parts and
- device spacing is typically associated with
  - the particular segment of the work zone and
  - the posted speed limit or operating speed of the roadway (Speed).

Below is a diagram showing the device spacing for a Typical Flagger Operation Taper.

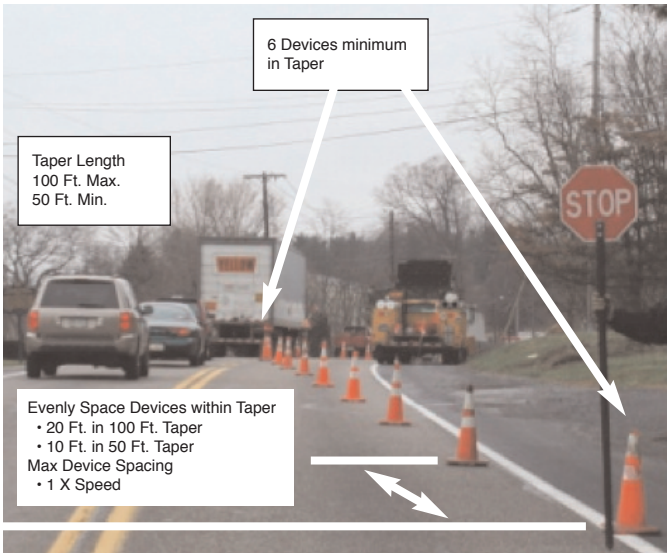

When setting up the taper, place the first and last devices in the taper along the edge line or in the shoulder, lay-out the other cones evenly between those two, and then move the devices laterally into the lane to be closed, delineating the taper.

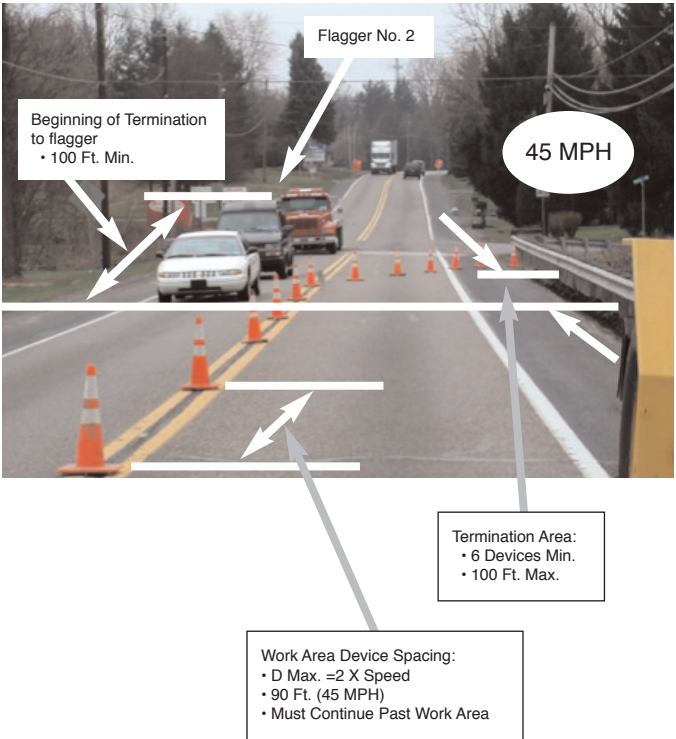

## Using and Adjusting Typical Applications

### Using and Adjusting Typical Applications

The MUTCD, Chapter 6G.01 indicates that the goal of TTC in work zones is safety with minimum disruption to road users. The key factor in promoting TTC zone safety is proper judgment.

PUB 213, in its General Notes indicates that all distances given in its typical drawings may be adjusted slightly to fit field conditions (Note 1). Further, Traffic Control Plans may deviate from the typical applications shown in the publication to allow for conditions and requirements of a particular site or jurisdiction (Note 3).

Following are common issues or scenarios requiring temporary traffic control. For each of these, a reference to the appropriate guidelines is given.



Below is a table from PATA 10a showing channelizing device spacing based upon speed.

<b>All Highways except Freeway and Expressway</b>		
MPH	D	E*
	Ft.	Ft.
25	50	155
30	60	200
35	70	250
40	80	305
45	90	360
50	100	425
55	110	495

Following are the NOTES from PATA 10a:

1. All flaggers must be in communication of each other.
2. Each flagger should be clearly visible to traffic for a minimum distance of E.
3. At night, flagger stations shall be illuminated, except in emergencies. (See general notes, sheet 3, note 26)
4. For operations of 15 minutes or less:
  - a. The N20-1 and the N20-4 signs are not required
  - b. All channelizing devices may be eliminated if a vehicle with an activated flashing or revolving yellow light is present in advance of the work space.
  - c. The N20-7A sign may be eliminated if the flagger is clearly visible to traffic for a minimum distance of E.
5. The buffer space should be extended so that the two-way traffic taper is placed before a horizontal (or crest vertical) curve to provide adequate sight distance for the flagger and a queue of stopped vehicles.
6. When a highway-rail grade crossing exists within the work zone, or it is anticipated that queues resulting from the lane closure might extend through a highway-rail grade crossing, provisions shall be made to eliminate conflicts, which may require placing a flagger at the crossing. Coordination with the railroad is essential.

## Low Volume Roads

The MUTCD, Typical Application 18, figure 6h-18, presents guidance for low volume roads. This figure shall be used only for low speed, low volume roads, and where work is short, where road users can see the roadway beyond, and where volume is low, traffic may be self regulating.

Following are the NOTES from figure 6H-18 – Typical Application 18:

### Lane Closure on a Minor Street

#### Standard:

1. This TTC shall be used only for low-speed facilities having low traffic volumes

#### Option:

2. Where the work space is short, where road users can see the roadway beyond, and where volume is low, vehicular traffic may be self-regulating.

#### Standard:

3. Where vehicular traffic cannot effectively self-regulate, one or two flaggers shall be used as illustrated in figure 6H-10.

#### Option:

4. Flashing warning lights and/or flags may be used to call attention to the advance warning signs.
5. A truck-mounted attenuator may be used on the work vehicle and the shadow vehicle.

**Figure 6H-18. Lane Closure on a Minor Street (TA-18)**

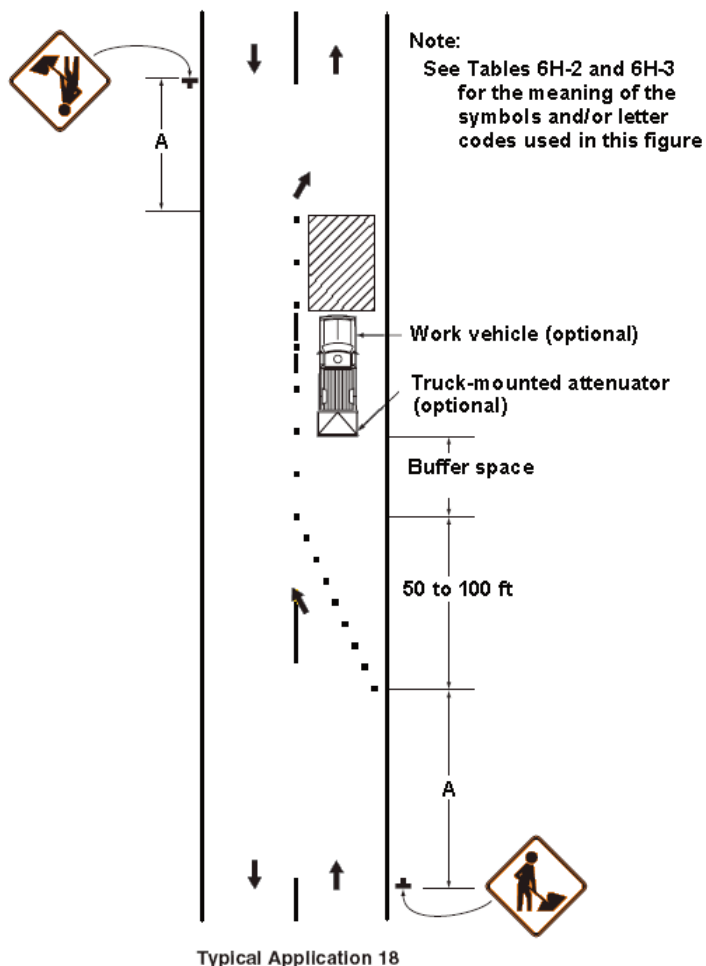

Following is PATA 11c showing a short-term road closure mobile operation on a two-lane, two-way roadway:

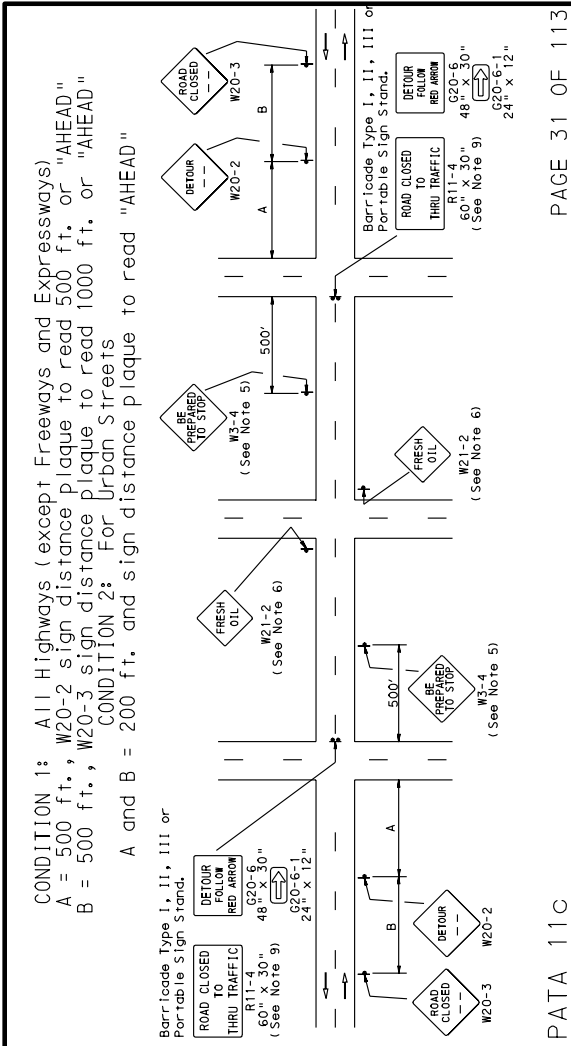

Following are the NOTES from PATA 11c:

1. This figure applies for operations that move intermittently at an average speed of 1 mph or less.
2. This setup is to be used during daylight hours only and only on roadways with ADT's of 1500 or less.
3. Hours of work should not interfere with rush hour traffic or school bus schedules and the work site must be capable of accommodating emergency vehicles with as little delay as possible.
4. Flaggers may be needed with the operations to control local traffic and at intersections. Flaggers must be in communication with each other.
5. The maximum distance between a flagger with the operation and a W3-4 Sign is 2 miles. Interim W3-4 Signs will be required for any project over 2 miles in length: however, if there will be no flaggers between the W3-4 sign and the R11-4 Sign. The W3-4 Sign should be removed or turned away from traffic.
6. The signing of intersecting roads with W21-1 Signs is required when the ADT of the Intersecting road is 200 or greater.
7. Roads used as alternate routes should be owned and maintain by the Commonwealth (Department projects only).
8. At locations where there are overlapping detours or several detours within the same area, street names may be added to the G20-6 and g20-6-1 signs, or signs with different colored arrows may be used to designate the different detour routes. The design and application of signs displaying colored arrows shall comply with the PUB 236M.
9. The R11-3A Sign may be used in place of the R11-4 sign.

Following is PATA 11e showing a road closure for a short-term, stationary operation on a two-lane, two-way roadway:

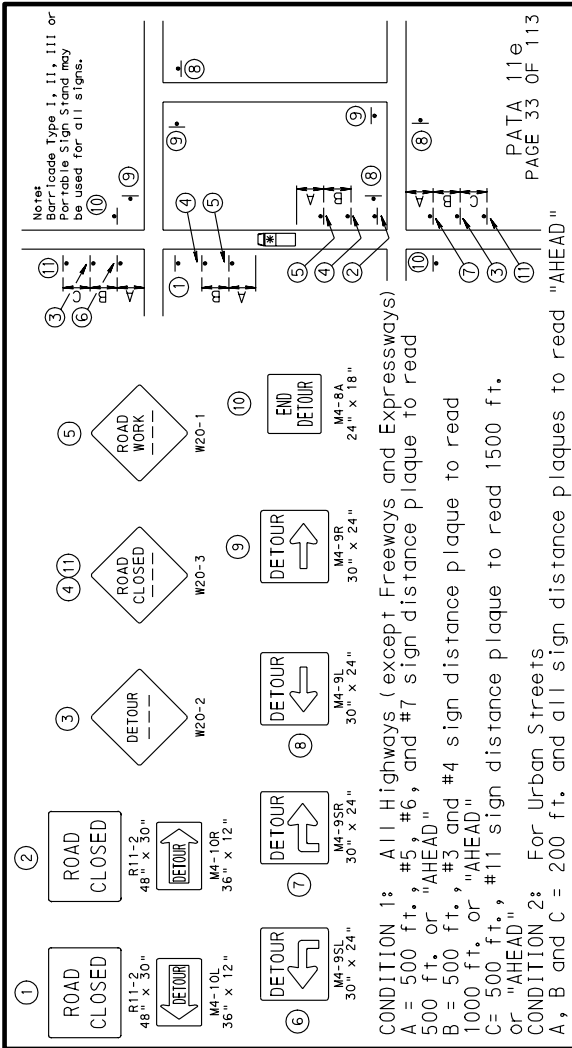

Following are the NOTES from PATA Figure 11e:

1. This figure applies for stationary operations where it is not feasible to maintain alternate one direction traffic flow
2. This setup is to be used during daylight hours only and only on roadways with ADT's of 1500 or less
3. Hours of work should not interfere with rush hour traffic or school bus schedules and the work area must be capable of accommodating emergency vehicles with as little delay as possible.
4. Roads used as alternate routes should be owned and maintained by the commonwealth (Department of projects only).
5. At locations where there are overlapping detours or several detours within the same area, street names may be added to the W4-9 series Signs, or signs with different colored arrows may be used to designate the different detour routes. The design and application of signs displaying colored arrows shall comply with PUB 236M.

Following is PATA 12 showing a short-term mobile operation on a two-lane, two-way roadway or one-lane approach of a three-lane, two-way roadway:

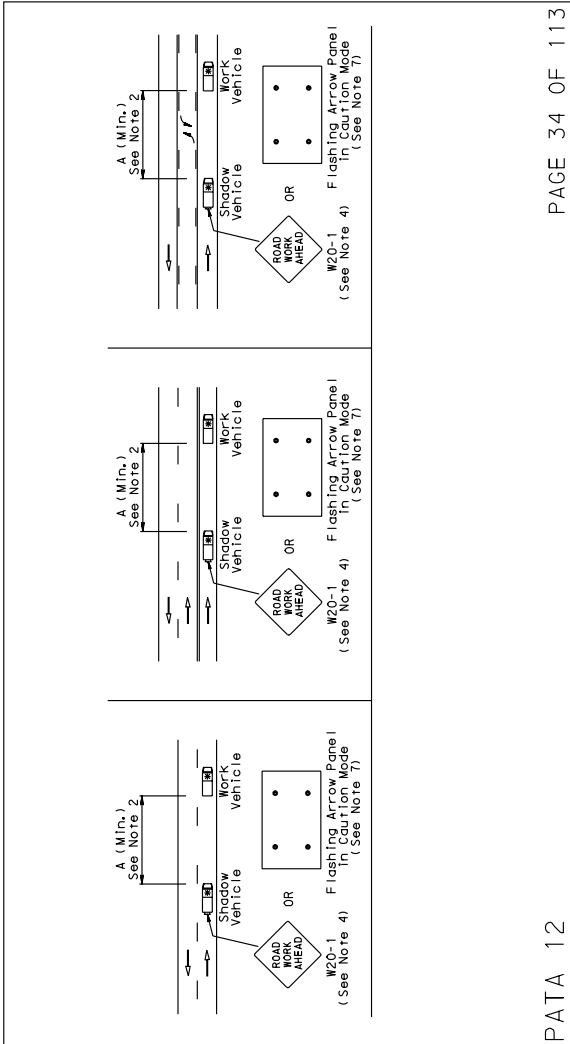

Following are the NOTES from PATA 12:

1. This figure applies for operations that move intermittently or continuously at an average speed of 1 mph or more. The shadow vehicle shall be positioned so that it is visible from behind for a minimum distance of A. the shadow vehicle should slow down in advance of vertical or horizontal curves that restrict sight distance.
2. Where passing is not permitted for extended lengths, the shadow and work vehicles should pull over periodically, when it is reasonable and safe, in order to allow “backed-up” or queued traffic to resume its normal speed.
3. Other appropriate standard signs may be used instead of the M20-1 Sign
4. The shadow vehicle should be equipped with two high-intensity flashing lights mounted on the rear, adjacent to the sign.
5. A truck-mounted attenuator may be used on the shadow vehicle and/or on the work vehicle.
6. See PATA general, table 5 for size of Flashing Arrow Panel.

## Options for Mowing

Mowing operations is a common activity along Pennsylvania's roadways. There are several ways to manage traffic flow for mowing depending upon roadway encroachment, type of roadway, traffic volumes, and speeds. Mowing is considered a mobile operation, and three PATA figures can apply:

- Flagging with two flaggers  
-PUB 213 PATA 11a
- Flagging with a single flagger  
-PATA 11b
- Shadow vehicle  
-PATA 12
- Exempt Work - mowing operations on roads with less than 10,000 vehicles per day and where equipment does not encroach on the roadway.
- Shadow vehicles for mowing operations are optional (Note 23, PATA 12).

## Work Zone Checklist for Short Term Set-ups

### Planning/Design

- Determine the type of work planned for the day.
- Schedule the work to avoid significantly impacting travel.
- Use PUB 213 PATA Figures to determine the appropriate work zone traffic control and devices.
- Document planned set-up and adjustments to PUB 213 PATA Figures
- If a flagger operation is planned, assign trained flaggers to the work.

### Preparing for Field

- Collect the devices to be used.
- Inspect devices to ensure all devices meet specification and visibility standards.
- Make sure all workers have appropriate safety apparel.

### In Field

- Measure and mark position for placement of devices at work site.
- Document any adjustments to device placement.
- Place devices following guidance from PUB 213, Note 18.
- Check that flaggers are positioned properly, attired correctly, and using correct methods.
- Drive-through to inspect work zone set-up and adjust any devices/flaggers as required.
- Conduct work.
- Check to ensure traffic is not backing up to create traffic problems or safety hazards.
- Finish work.

- Remove equipment, materials, and personnel.
- Remove devices following guidance from PUB 213, Note 18.

***Get in, Get out, and Stay out!***